

ULTRABASS

BX1800

User's manual



Version 1.2 April 2006



www.behringer.com



ULTRABASS BX1800

IMPORTANT SAFETY INSTRUCTIONS



CAUTION: To reduce the risk of electric shock, do not remove the top cover (or the rear section). No user serviceable parts inside; refer servicing to qualified personnel.

WARNING: To reduce the risk of fire or electric shock, do not expose this appliance to rain and moisture. The apparatus shall not be exposed to dripping or splashing and no objects filled with liquids, such as vases, shall be placed on the apparatus.



This symbol, wherever it appears, alerts you to the presence of uninsulated dangerous voltage inside the enclosure—voltage that may be sufficient to constitute a risk of shock.



This symbol, wherever it appears, alerts you to important operating and maintenance instructions in the accompanying literature. Please read the manual.

DETAILED SAFETY INSTRUCTIONS:

- 1) Read these instructions.
- 2) Keep these instructions.
- 3) Heed all warnings.
- 4) Follow all instructions.
- 5) Do not use this apparatus near water.
- 6) Clean only with dry cloth.
- 7) Do not block any ventilation openings. Install in accordance with the manufacturer's instructions.
- 8) Do not install near any heat sources such as radiators, heat registers, stoves, or other apparatus (including amplifiers) that produce heat.
- 9) Do not defeat the safety purpose of the polarized or grounding-type plug. A polarized plug has two blades with one wider than the other. A grounding type plug has two blades and a third grounding prong. The wide blade or the third prong are provided for your safety. If the provided plug does not fit into your outlet, consult an electrician for replacement of the obsolete outlet.
- 10) Protect the power cord from being walked on or pinched particularly at plugs, convenience receptacles, and the point where they exit from the apparatus.
- 11) Only use attachments/accessories specified by the manufacturer.
- 12) Use only with the cart, stand, tripod, bracket, or table specified by the manufacturer, or sold with the apparatus. When a cart is used, use caution when moving the cart/apparatus combination to avoid injury from tip-over.



13) Unplug this apparatus during lightning storms or when unused for long periods of time.

14) Refer all servicing to qualified service personnel. Servicing is required when the apparatus has been damaged in any way, such as power supply cord or plug is damaged, liquid has been spilled or objects have fallen into the apparatus, the apparatus has been exposed to rain or moisture, does not operate normally, or has been dropped.

15) **CAUTION** - These service instructions are for use by qualified service personnel only. To reduce the risk of electric shock do not perform any servicing other than that contained in the operation instructions unless you are qualified to do so.

ULTRABASS

180-Watt Bass Workstation with Original BUGERA™ Speaker and VTC-Technology

- ▲ Powerful and ultra-compact 180-Watt Bass Workstation
- ▲ Original BUGERA™ 15" special high-impact cone speaker
- ▲ Custom-made horn tweeter for high-end punch
- ▲ VTC Virtual Tube Circuitry for tube-like sound
- ▲ Dedicated 4-band EQ and Mid Shape function for awesome sound shaping
- ▲ Musical opto-limiter for ultimate volume without distortion
- ▲ Separate headphone output—perfect for quiet practicing
- ▲ Balanced XLR DI and Ground Lift switch for direct connection to your mixing console
- ▲ CD input allows you to play along to your favorite music
- ▲ FX Insert for external effects devices (stomp boxes, rack effects, etc.)
- ▲ High-quality components and exceptionally rugged construction ensure long life
- ▲ Conceived and designed by BEHRINGER Germany

GB

BX1800

FOREWORD



Dear Customer,

Welcome to the team of ULTRABASS users and thank you very much for expressing your confidence in BEHRINGER products by purchasing the BEHRINGER BX1800.

It is one of my most pleasant tasks to write this letter to you, because it is the culmination of many months of hard work delivered by our engineering team to reach a very ambitious goal: to present you with an outstanding bass workstation that gives you maximum flexibility and performance with

its unique sound character and broad range of functions.

The task to design the new ULTRABASS certainly meant a great deal of responsibility, which we assumed by focusing on you, the discerning user and musician. It also meant a lot of work and night shifts to accomplish this goal. But it was fun, too. Developing a product usually brings a lot of people together, and what a great feeling it is when everybody who participated in such a project can be proud of what we've achieved.

It is our philosophy to share our joy with you, because you are the most important member of the BEHRINGER team. With your highly competent suggestions for new products you've greatly contributed to shaping our company and making it successful. In return, we guarantee you uncompromising quality as well as excellent technical and audio properties at an extremely favorable price. All of this will enable you to fully unfold your creativity without being hampered by budget constraints.

We are often asked how we can produce such high-grade devices at such unbelievably low prices. The answer is quite simple: it's you, our customers! Many satisfied customers means large sales volumes enabling us to get better conditions of purchase for components, etc. Isn't it only fair to pass this benefit back to you? Because we know that your success is our success, too!

I would like to thank all people whose help on "Project ULTRABASS" has made it all possible. Everybody has made very personal contributions, starting from the designers of the unit to the many staff members in our company and finally to you, the users of BEHRINGER products.

My friends, it's been worth the trouble!

Thank you very much,

Uli Behringer

TABLE OF CONTENTS

1. INTRODUCTION	4
1.1 Before you get started	5
1.1.1 Shipment	5
1.1.2 Initial operation	5
1.1.3 Online registration	5
2. WIRING TIPS	5
3. CONTROL ELEMENTS	6
4. AUDIO CONNECTIONS	7
5. SPECIFICATIONS	7
6. WARRANTY	8

1. INTRODUCTION

With the BX1800 you have acquired a state-of-the-art Bass Workstation that sets new standards in bass amp engineering. Right from the start, our goal has been to design a revolutionary amp that stands out from the herd of "ordinary" bass amplifiers. And indeed, the BX1800 gives you plenty of functionality and a broad range of connection and expansion options. In short: you'll be fascinated to find that the BX1800 is a Workstation with a character.

VTC Virtual Tube Circuitry

The VTC Virtual Tube Circuitry was specially developed to lend the bass sound the unique character of classic tube amps.

Jam it up!

With its CD player input, your BX1800 is the ultimate practice amp, because it couldn't be easier to play along to your favorite music. If you don't want anybody listening to what you're playing, or simply wish to avoid disturbing the neighbors, just use your headphones. The BEHRINGER HPS3000 is ideal just for that.

Please read the manual carefully and keep it around for future reference.

ATTENTION!

High volume levels can damage your hearing or your headphones. Please turn down the VOLUME control to zero (all the way to the left) before you power up the amp. Always make sure you use appropriate volume levels.

1.1 Before you get started

1.1.1 Shipment

Your BX1800 was carefully packed at the factory, and the packaging was designed to protect the unit from rough handling. Nevertheless, we recommend that you carefully examine the packaging and its contents for any signs of physical damage that may have occurred during transit.

- 👉 **If the unit is damaged, please do NOT return it to BEHRINGER. Instead, notify your dealer and the shipping company immediately. Otherwise, claims for damage or replacement may not be honored.**
- 👉 **Always use the original packing carton to prevent damage during storage or transport.**
- 👉 **Make sure that no children are left unsupervised with the BX1800 or its packaging.**
- 👉 **Please ensure proper disposal of all packing materials.**

1.1.2 Initial operation

Be sure that there is enough space around the unit for cooling. To avoid overheating, please do not place the ULTRABASS near radiators and other equipment emanating heat.

- 👉 **Please keep in mind that all the equipment has to be grounded at all times. For your own protection, never change or disable the grounding on your equipment or on the cables! The unit shall always be connected to the mains socket outlet with a protective earthing connection.**

1.1.3 Online registration

Please do remember to register your new BEHRINGER equipment right after your purchase by visiting www.behringer.com (alternatively www.behringer.de) and kindly read the terms and conditions of our warranty carefully.

Should your BEHRINGER product malfunction, our goal is to have it repaired as quickly as possible. To arrange for warranty service, please contact the retailer from whom the equipment was purchased. Should your BEHRINGER dealer not be located in your vicinity, you may directly contact one of our subsidiaries. Corresponding contact information is included in the original equipment packaging (Global Contact Information/European Contact Information). Should your country not be listed, please contact the distributor nearest you. A list of distributors can be found in the support area of our website (www.behringer.com).

Registering your purchase and equipment with us helps us process your repair claims quicker and more efficiently.

Thank you for your cooperation!

2. WIRING TIPS

Figures 2.1 and 2.2 show you how to connect your bass to the amplifier.

If you want to use an effects unit (for example, the BEHRINGER X V-AMP PRO) to experiment with some out-of-the-ordinary sounds, you can connect your bass directly to the input of the unit. Then, connect a second cable from the effects output to the input on your bass amp.

If you have an electronic tuner, please be sure to insert it pre effects device, so that the tuner only receives a dry signal without effects components.

X V-AMP PRO: no additional tuner required.

- 👉 **The built-in loudspeaker is disabled automatically when you plug in the headphones.**

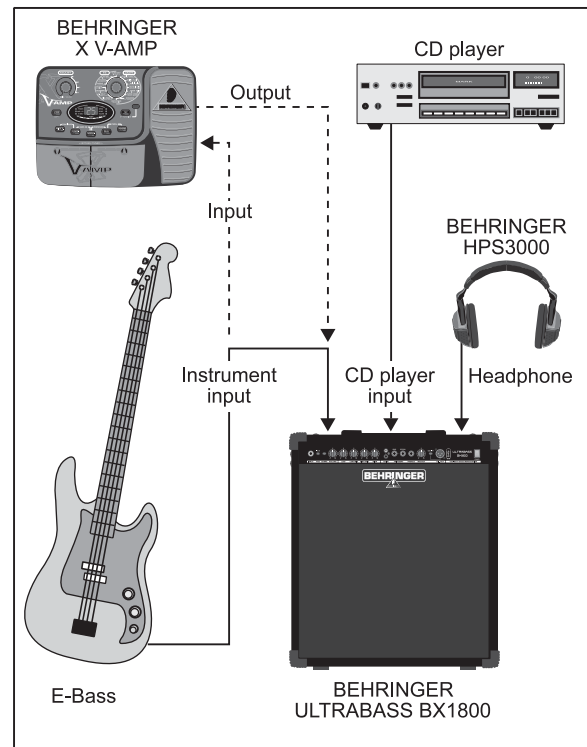

Fig. 2.1: Example of a setup using the ULTRABASS BX1800

Fig. 2.2 shows a recommended setup for amplifying the sound of your BX1800 using a sound reinforcement system of any size. This way, you can also use your amp for playing live or for rehearsals with your band.

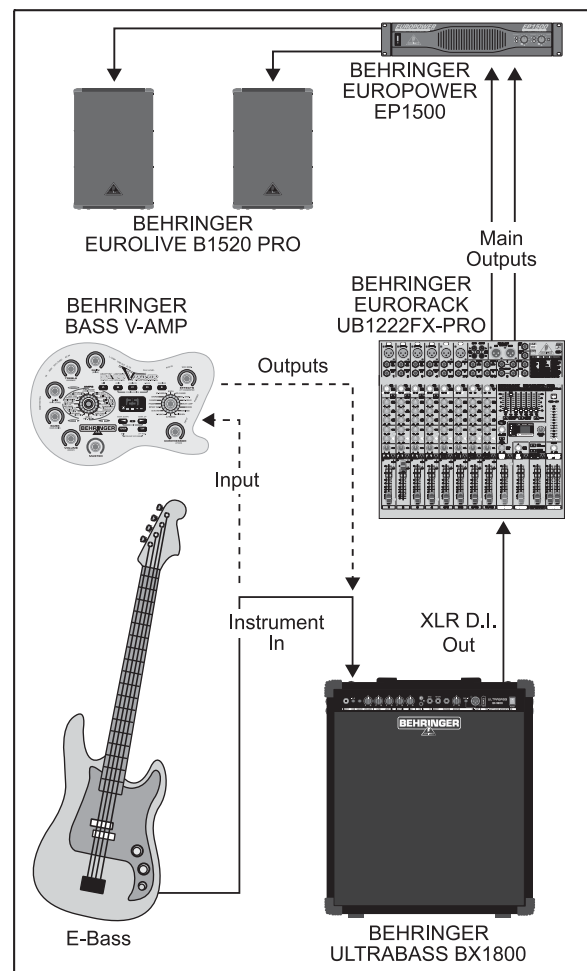

Fig. 2.2: Live setup

ULTRABASS BX1800

3. CONTROL ELEMENTS

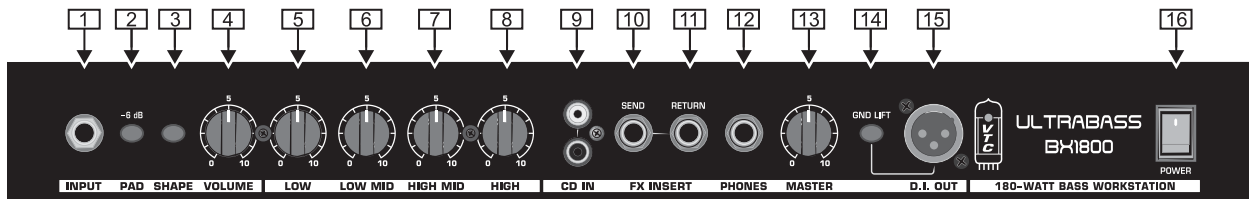

Fig. 3.1: Front view

- 1 Connect your bass to the *INPUT* jack, using a standard cable with a 1/4" TS connector.
 - 2 Press the *PAD* switch when using active instruments with high output levels. In this case the *INPUT* jack features 6 dB less gain. For passive instruments the *PAD* button has to be depressed.
 - 3 Pressing the *SHAPE* button will activate the Shape function. The Shape function on your BX1800 provides a revolutionary type of filter that you can use to modify your bass sound.
 - 4 Use the *VOLUME* control to adjust the volume of the instrument channel. To change the balance between the instrument and CD volume level, use your instrument's volume control.
 - 5 The *LOW* control allows you to boost or cut the low-frequency range.
 - 6 Using the *LOW MID* control you can boost or cut the lower mids.
 - 7 The *HIGH MID* control allows you to boost or cut the upper mids.
 - 8 The *HIGH* control governs the high-frequency range to give your bass a more "cutting" sound.
 - 9 Use the *CD IN* connectors to connect the output of your CD player, tape deck, CD or MD walkman. This way you can play along to music or bass guitar tutorial CDs.
 - 10 The BX1800 features an *FX INSERT*-Loop for external effects. Connect the *SEND* output to the input of your effects device, for example, our proven multi-effects processor BEHRINGER VIRTUALIZER PRO DSP2024P. This output can also be used to connect your tuner.
 - 11 Connect the *RETURN* jack to the output of your effects device. Since the BX1800 features a serial effects path, the mix ratio must be set on your effects device.
 - 12 The *PHONES* jack is for headphones. When you plug in your headphones, the built-in loudspeaker is muted.
 - 13 Use the *MASTER* control to adjust the output level of the D.I. OUT output.
 - 14 The *GND LIFT* switch disconnects (switch pressed) the ground connection at the D.I. OUT output to effectively eliminate hum noise resulting from ground loops.
 - 15 Use the balanced *D.I. OUT* XLR output to feed the audio signal from your ULTRABASS to an external mixing console. The D.I. OUT signal is post-EQ.
 - 16 Use the *POWER* switch to switch the BX1800 on or off. You should always make sure that the *POWER* switch is in the "Off" position when initially connecting the unit to the mains.

To disconnect the unit from the mains, pull out the main cord plug. When installing the product, ensure that the plug is easily accessible.
- Please note: Merely switching the unit off does not mean that it is fully disconnected from the mains. When not using the unit for prolonged periods of time, please unplug the unit's power cord from the power outlet.**

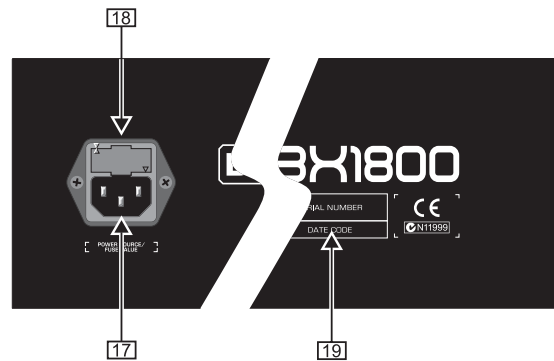

Fig. 3.2 Rear view

- 17 **MAINS CONNECTION.** Use the power cord supplied with the unit to connect it to the mains.
- 18 **FUSE HOLDER/VOLTAGE SELECTOR.** Before connecting the unit to the mains, make sure that the voltage setting matches your local voltage. A blown fuse should only be replaced by a fuse of the same type and rating. On some units, the fuse holder can be switched to one of two positions, i.e. 230 V and 120 V. When operating the unit outside Europe at 120 V, a higher fuse rating is required.
- 19 **SERIAL NUMBER.**

4. AUDIO CONNECTIONS

Except for the D.I. OUT output which is on a balanced XLR connector, your BEHRINGER ULTRABASS BX1800 features 1/4" connectors on inputs and output. More detailed information can be found in chapter 5, "SPECIFICATIONS."

⚠ Please keep in mind that all the equipment has to be grounded at all times. For your own protection, never change or disable the grounding on your equipment or on the cables! The unit shall always be connected to the mains socket outlet with a protective earthing connection.

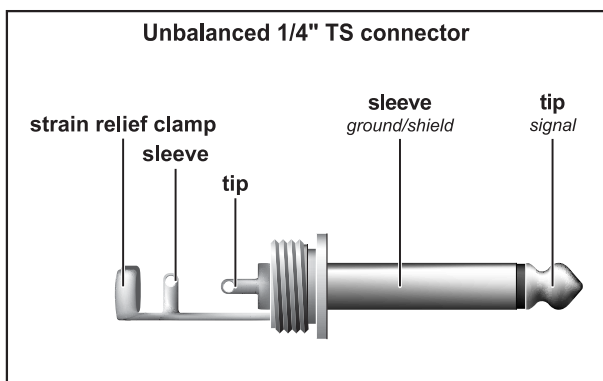

Fig. 4.1: 1/4" mono connector (TS) for the INPUT

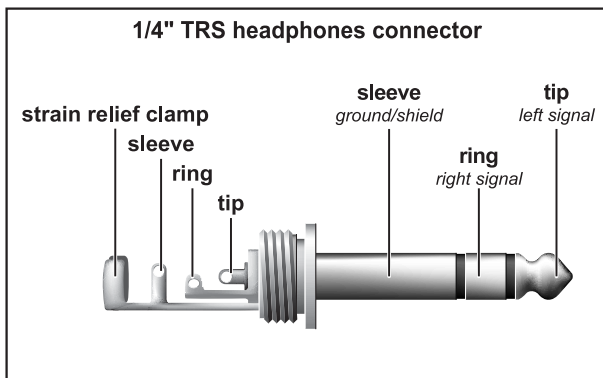

Fig. 4.2: 1/4" stereo connector (TRS) for headphones

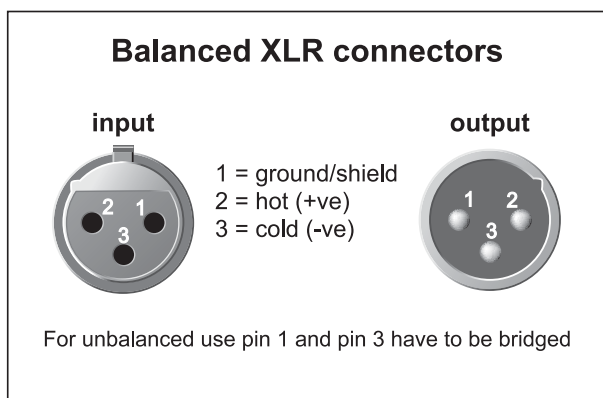

Fig. 4.3: XLR connectors

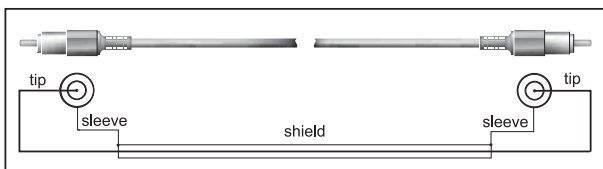

Fig. 4.4: RCA cable

5. SPECIFICATIONS

AUDIO INPUTS

Active instrument input	1/4" mono jack, unbalanced
Input impedance	approx. 220 kΩ unbalanced
Passive instrument input	1/4" mono jack, unbalanced
Input impedance	approx. 730 kΩ unbalanced
Return	1/4" mono jack, unbalanced
Input impedance	approx. 15 kΩ unbalanced
CD input	RCA, unbalanced

AUDIO OUTPUTS

Send	1/4" mono jack, unbalanced
Output impedance	min. 2 kΩ unbalanced
D.I. Out	XLR connector, servo-balanced
Output impedance	approx. 100 Ω balanced
Output level	max. 0 dBu

SYSTEM DATA

Power amp output	180 Watts
------------------	-----------

LOUDSPEAKER

High-power bass speaker	15" BUGERA Classic Tone Series
Tweeter	custom-made horn tweeter

POWER SUPPLY

Mains voltages	U.S./Canada
	120 V~, 60 Hz
	Europe/U.K./Australia
	230 V~, 50 Hz
	China
	220 V~, 50 Hz
	Japan
	100 V~, 50 - 60 Hz
	General export model
	120/230 V~, 50 - 60 Hz
Power consumption	max. 290 W
Fuse	100 - 120 V~: T 6.3 A H 250 V
	200 - 240 V~: T 3.15 A H 250 V
Mains connection	Standard IEC receptacle

DIMENSIONS/WEIGHT

Dimensions (H x W x D)	approx. 570 mm (22 1/2")
	x 312 mm (12 3/10")
	x 507 mm (20")
Weight	approx. 25.1 kg (55.35 lbs)

BEHRINGER is constantly striving to maintain the highest professional standards. As a result of these efforts, modifications may be made from time to time to existing products without prior notice. Specifications and appearance may differ from those listed or shown.



6. WARRANTY

§ 1 OTHER WARRANTY RIGHTS AND NATIONAL LAW

1. This warranty does not exclude or limit the buyer's statutory rights provided by national law, in particular, any such rights against the seller that arise from a legally effective purchase contract.

2. The warranty regulations mentioned herein are applicable unless they constitute an infringement of national warranty law.

§ 2 ONLINE REGISTRATION

Please do remember to register your new BEHRINGER equipment right after your purchase by visiting www.behringer.com (alternatively www.behringer.de) and kindly read the terms and conditions of our warranty carefully. Registering your purchase and equipment with us helps us process your repair claims quicker and more efficiently. Thank you for your cooperation!

§ 3 WARRANTY

1. BEHRINGER (BEHRINGER International GmbH including all BEHRINGER subsidiaries listed on the enclosed page, except BEHRINGER Japan) warrants the mechanical and electronic components of this product to be free of defects in material and workmanship for a period of one (1) year* from the original date of purchase, in accordance with the warranty regulations described below. If the product shows any defects within the specified warranty period that are not excluded from this warranty as described under § 5, BEHRINGER shall, at its discretion, either replace or repair the product using suitable new or reconditioned parts. In the case that other parts are used which constitute an improvement, BEHRINGER may, at its discretion, charge the customer for the additional cost of these parts.

2. If the warranty claim proves to be justified, the product will be returned to the user freight prepaid.

3. Warranty claims other than those indicated above are expressly excluded.

§ 4 RETURN AUTHORIZATION NUMBER

1. To obtain warranty service, the buyer (or his authorized dealer) must call BEHRINGER (see enclosed list) during normal business hours **BEFORE** returning the product. All inquiries must be accompanied by a description of the problem. BEHRINGER will then issue a return authorization number.

2. Subsequently, the product must be returned in its original shipping carton, together with the return authorization number to the address indicated by BEHRINGER.

3. Shipments without freight prepaid will not be accepted.

§ 5 WARRANTY REGULATIONS

1. Warranty services will be furnished only if the product is accompanied by a copy of the original retail dealer's invoice. Any product deemed eligible for repair or replacement under the terms of this warranty will be repaired or replaced.

2. If the product needs to be modified or adapted in order to comply with applicable technical or safety standards on a national or local level, in any country which is not the country for which the product was originally developed and manufactured, this modification/adaptation shall not be considered a defect in materials or workmanship. The warranty does not cover any such modification/adaptation, irrespective of whether it was carried out properly or not. Under the terms of this warranty, BEHRINGER shall not be held responsible for any cost resulting from such a modification/adaptation.

3. Free inspections and maintenance/repair work are expressly excluded from this warranty, in particular, if caused by improper handling of the product by the user. This also applies to defects caused by normal wear and tear, in particular, of faders, crossfaders, potentiometers, keys/buttons, tubes, guitar strings, illuminants and similar parts.

4. Damages/defects caused by the following conditions are not covered by this warranty:

- ▲ improper handling, neglect or failure to operate the unit in compliance with the instructions given in BEHRINGER user or service manuals.
- ▲ connection or operation of the unit in any way that does not comply with the technical or safety regulations applicable in the country where the product is used.
- ▲ damages/defects caused by force majeure or any other condition that is beyond the control of BEHRINGER.

5. Any repair or opening of the unit carried out by unauthorized personnel (user included) will void the warranty.

6. If an inspection of the product by BEHRINGER shows that the defect in question is not covered by the warranty, the inspection costs are payable by the customer.

7. Products which do not meet the terms of this warranty will be repaired exclusively at the buyer's expense. BEHRINGER will inform the buyer of any such circumstance. If the buyer fails to submit a written repair order within 6 weeks after notification, BEHRINGER will return the unit C.O.D. with a separate invoice for freight and packing. Such costs will also be invoiced separately when the buyer has sent in a written repair order.

§ 6 WARRANTY TRANSFERABILITY

This warranty is extended exclusively to the original buyer (customer of retail dealer) and is not transferable to anyone who may subsequently purchase this product. No other person (retail dealer, etc.) shall be entitled to give any warranty promise on behalf of BEHRINGER.

§ 7 CLAIM FOR DAMAGES

Failure of BEHRINGER to provide proper warranty service shall not entitle the buyer to claim (consequential) damages. In no event shall the liability of BEHRINGER exceed the invoiced value of the product.

* Customers in the European Union please contact BEHRINGER Germany Support for further details.

Technical specifications and appearance subject to change without notice. The information contained herein is correct at the time of printing. The names of companies, institutions or publications pictured or mentioned and their respective logos are registered trademarks of their respective owners. Their use neither constitutes a claim of the trademarks by BEHRINGER® nor affiliation of the trademark owners with BEHRINGER®. BEHRINGER® accepts no liability for any loss which may be suffered by any person who relies either wholly or in part upon any description, photograph or statement contained herein. Colours and specification may vary slightly from product. Products are sold through our authorised dealers only. Distributors and dealers are not agents of BEHRINGER® and have absolutely no authority to bind BEHRINGER® by any express or implied undertaking or representation. No part of this manual may be reproduced or transmitted in any form or by any means, electronic or mechanical, including photocopying and recording of any kind, for any purpose, without the express written permission of BEHRINGER Spezielle Studioteknik GmbH. BEHRINGER® is a registered trademark.

ALL RIGHTS RESERVED. © 2006 BEHRINGER Spezielle Studioteknik GmbH,
Hanns-Martin-Schleyer-Str. 36-38, 47877 Willich-Münchheide II, Germany.
Tel. +49 2154 9206 0, Fax +49 2154 9206 4903