



# CM-67

ORDERCODE D1366



***SHOWELECTRONICS FOR PROFESSIONALS***

## **Congratulations!**

You have bought a great, innovative product from DAP Audio.

The DAP Audio Microphone range brings excitement to any venue. Whether you want simple plug-&-play action or a sophisticated show, this product provides the effect you need.

You can rely on DAP Audio, for more excellent audio products.

We design and manufacture professional audio equipment for the entertainment industry.

New products are being launched regularly. We work hard to keep you, our customer, satisfied.

You can get some of the best quality, best priced products on the market from DAP Audio.

So next time, turn to DAP Audio for more great audio equipment.

Always get the best -- with DAP Audio !

Thank you!



# DAP Audio

---

## DAP Audio CM-67 Product Guide

|   |   |
|---|---|
| <b>Warning</b> .....                                | 2 |
| Unpacking Instructions.....                         | 2 |
| Safety-instructions.....                            | 2 |
| Operating Determinations.....                       | 3 |
| Return Procedure.....                               | 3 |
| Claims.....   | 3 |
| <b>Description</b> .....                            | 4 |
| Features.....                                       | 4 |
| Overview.....                                       | 4 |
| The Microphone.....                                 | 5 |
| Switching the internal rumble filter on or off..... | 5 |
| <b>Set Up and Operation</b> .....                   | 6 |
| <b>Frequency and Polar patterns</b> .....           | 6 |
| <b>Connection Cables</b> .....                      | 7 |
| <b>Maintenance</b> .....                            | 8 |
| <b>Product Specifications</b> .....                 | 8 |

# WARNING

**FOR YOUR OWN SAFETY, PLEASE READ THIS USER MANUAL CAREFULLY BEFORE YOUR INITIAL START-UP!**

## Unpacking Instructions

Immediately upon receiving this product, carefully unpack the carton and check the contents to ensure that all parts are present, and have been received in good condition. Notify the dealer immediately and retain packing material for inspection if any parts appear damaged from shipping or the carton itself shows signs of mishandling. Save the carton and all packing materials. In the event that a fixture must be returned to the factory, it is important that the fixture be returned in the original factory box and packing.

Your shipment includes:

- DAP CM-67
- Microphone Protection Bag
- Shockmount
- User Manual

 **CAUTION!**   
**Keep this system away from rain and moisture!**

## SAFETY INSTRUCTIONS

Every person involved with the installation, operation and maintenance of this system has to:

- be qualified
- follow the instructions of this manual

 **CAUTION! Be careful with your operations.**   
**With a dangerous voltage you can suffer a dangerous electric shock when touching the wires!**

Before you initial start-up, please make sure that there is no damage caused by transportation. Should there be any, consult your dealer and do not use the system.

To maintain perfect condition and to ensure a safe operation, it is absolutely necessary for the user to follow the safety instructions and warning notes written in this manual.

Please consider that damages caused by manual modifications to the system are not subject to warranty.

This system contains no user-serviceable parts. Refer servicing to qualified technicians only.

## IMPORTANT:

*The manufacturer will not accept liability for any resulting damages caused by the non-observance of this manual or any unauthorized modification to the system.*

- Never remove warning or informative labels from the unit.
- Do not open the device and do not modify the device.
- Only use system indoor, avoid contact with water or other liquids.
- Avoid flames and do not put close to flammable liquids or gases.
- Make sure you don't use the wrong kind of cables or defective cables.
- Make sure that the signals to the mixer are balanced, otherwise hum could be created.
- Don't put your equipment next to TV, radio, etc., because of interference or distortion.

- Please read this manual carefully and keep it for future reference. Remember that the device has a better value on the market, if you save the carton and all packing materials.
- If your Dap Audio device fails to work properly, discontinue use immediately. Pack the unit securely (preferably in the original packing material), and return it to your Dap Audio dealer for service.
- If the device has been exposed to drastic temperature fluctuation (e.g. after transportation), do not switch it on immediately. The arising condensation water might damage your system. Leave the system switched off until it has reached room temperature.
- Repairs, servicing and electric connection must be carried out by a qualified technician.

## OPERATING DETERMINATIONS

If this system is operated in any other way, than the one described in this manual, the product may suffer damages and the warranty becomes void.

Any other operation may lead to dangers like short-circuit, burns, electric shock, etc.

You endanger your own safety and the safety of others!

***Improper installation can cause serious damage to people and property !***

### **Return Procedure**

Returned merchandise must be sent prepaid and in the original packing, call tags will not be issued. Package must be clearly labeled with a Return Authorization Number (RMA number). Products returned without an RMA number will be refused. Highlite will not accept the returned goods or any responsibility. Call Highlite 0031-455667723 or mail [offersales@highlite.nl](mailto:offersales@highlite.nl) and request an RMA prior to shipping the fixture. Be prepared to provide the model number, serial number and a brief description of the cause for the return. Be sure to properly pack fixture, any shipping damage resulting from inadequate packaging is the customer's responsibility. Highlite reserves the right to use its own discretion to repair or replace product(s). As a suggestion, proper UPS packing or double-boxing is always a safe method to use.

**Note: If you are given an RMA number, please include the following information on a piece of paper inside the box:**

- 1) Your name
- 2) Your address
- 3) Your phone number
- 4) A brief description of the symptoms

### **Claims**

The client has the obligation to check the delivered goods immediately upon delivery for any shortcomings and/or visible defects, or perform this check after our announcement that the goods are at their disposal. Damage incurred in shipping is the responsibility of the shipper; therefore the damage must be reported to the carrier upon receipt of merchandise.

It is the customer's responsibility to notify and submit claims with the shipper in the event that a fixture is damaged due to shipping. Transportation damage has to be reported to us within one day after receipt of the delivery.

Any return shipment has to be made post-paid at all times. Return shipments must be accompanied with a letter defining the reason for return shipment. Non-prepaid return shipments will be refused, unless otherwise agreed in writing.

Complaints against us must be made known in writing or by fax within 10 working days after receipt of the invoice. After this period complaints will not be handled anymore.

Complaints will only then be considered if the client has so far complied with all parts of the agreement, regardless of the agreement of which the obligation is resulting.

## Description of the device

### Features

The DAP CM-67 is a large diaphragm condenser-microphone for recording purposes. But it can always be used for sound reinforcement in not so rough situations like acoustic ensembles or orchestras.

- Heavy duty aircraft grade machined brass body with a durable, scratch resistant anodized finish
- Built in (switchable) rumble filter
- Shockmount included
- Microphone protection bag included

### Overview



1. Head
2. Body
3. Bottom
4. XLR male output

## The microphone

Rugged construction, high SPL handling in a compact chassis makes the CM-67 an ideal choice for live sound reinforcement or live recording applications. It is also an ideal choice as a utility microphone for home or project studios where performance is required, yet budget is a concern.

The CM-67 can easily be used as an overhead mic. for drum kits, for guitar and bass cabinets or anywhere where superior sound quality and high sound pressure handling is required. The CM-67 is also the microphone of choice for vocals saxophone, flutes, brass or woodwinds, acoustic guitar or acoustic bass where subtlety and clarity is needed.

In live sound applications and remote recording, the CM-67's cardioid pattern offers excellent feedback rejection, better isolation and will give you the best results on most vocal applications and a wide range solo instruments, including background, brass and woodwinds, acoustic stringed instruments (violin, cello etc.), drums and percussion.

**Note: The cardioid symbol on the microphone housing denotes the live side, or front face of the microphone that in all cases should face the recording source.**

## Switching the internal low cut filter on or off

The CM-67 is a professional medium diaphragm condenser microphone with an internal -6dB 100Hz low cut filter switch. To operate the low cut switch, unscrew the bottom of the microphone housing, slide the microphone body from the chassis.

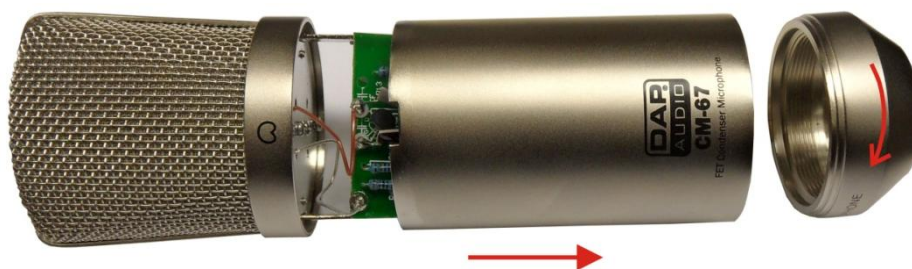

Look for the blue switch in the middle of the microphone circuit board. Pressing the switch activates the low cut filter.

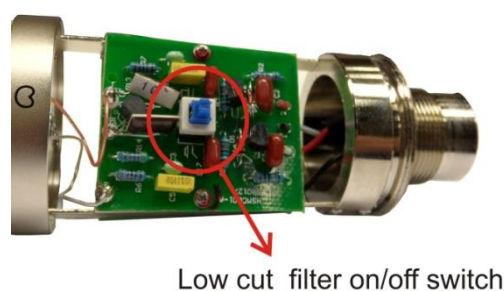

In virtual all recording or live sound applications, the low cut filter should be engaged to reduce handling noise and low frequency rumble.

## Set Up and Operation

It is always advisable to use a pop filter (not included) when recording vocals, not only to avoid overly accentuated 'S', 'P' and 'B' sounds, but also to protect the element from moisture (spit). It is always a good idea to store the microphone in its protection bag when not in use.

Connect the microphone to a mixer or recording device with a high quality XLR cable before turning on the phantom power. Make sure all volume and gain controls on your mixer, mic preamp or recording device are at their minimum volume settings when switching the phantom power on.

Once the CM-67 is plugged in and the phantom power is switched on, Move the channel fader gradually to the 0dB position adjust the input gain using your channel peak led or VU-meter.

## Frequency and Polar Diagrams

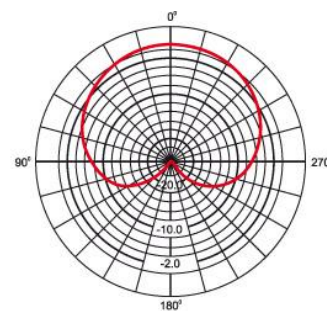
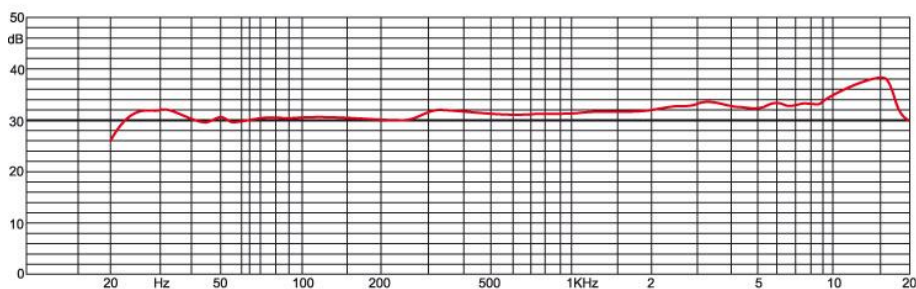

Cardioid at 1KHz



# Connection Cables

Take care of the connector cables, always holding them by the connectors and avoiding knots and twists when coiling them: This gives the advantage of increasing their life and reliability, which is always to your advantage.

Periodically check that your cables are in good condition, that they are correctly wired and that all their contacts are in good condition: a great number of problems (faulty contacts, ground hum, discharges, etc.) are caused entirely by using unsuitable or faulty cables.

Headphones

Unbalanced mono 1/4" jack plug

Balanced mono 1/4" jack plug

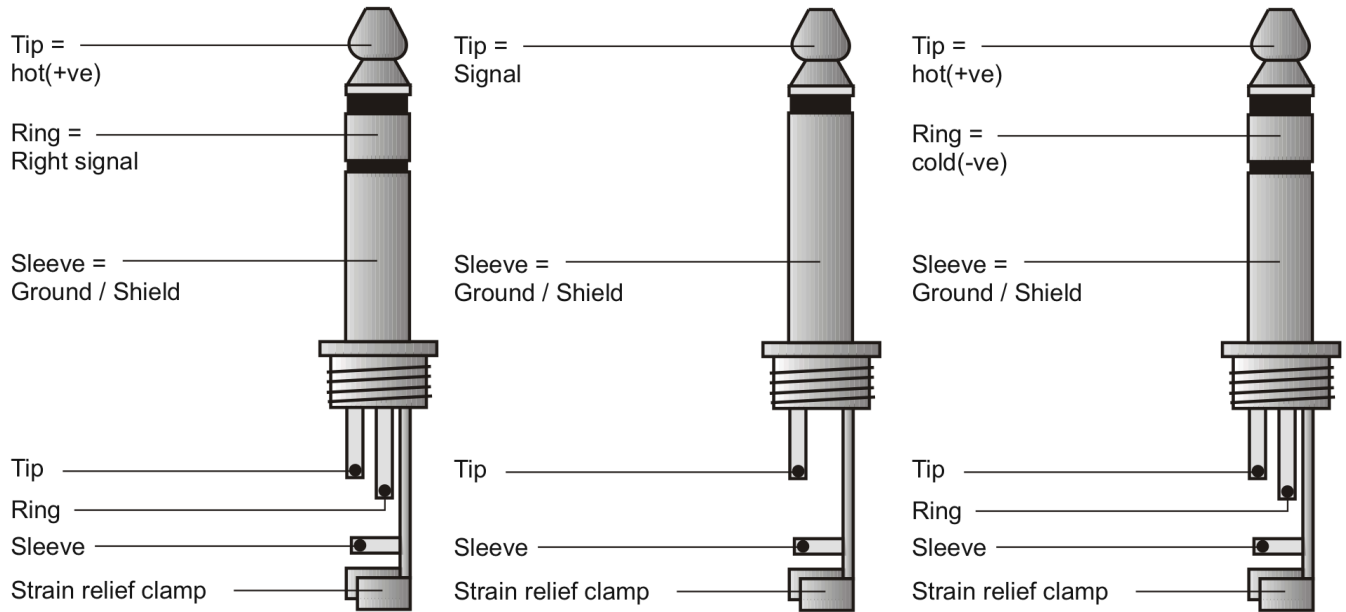

## Compensation of interference with balanced connections

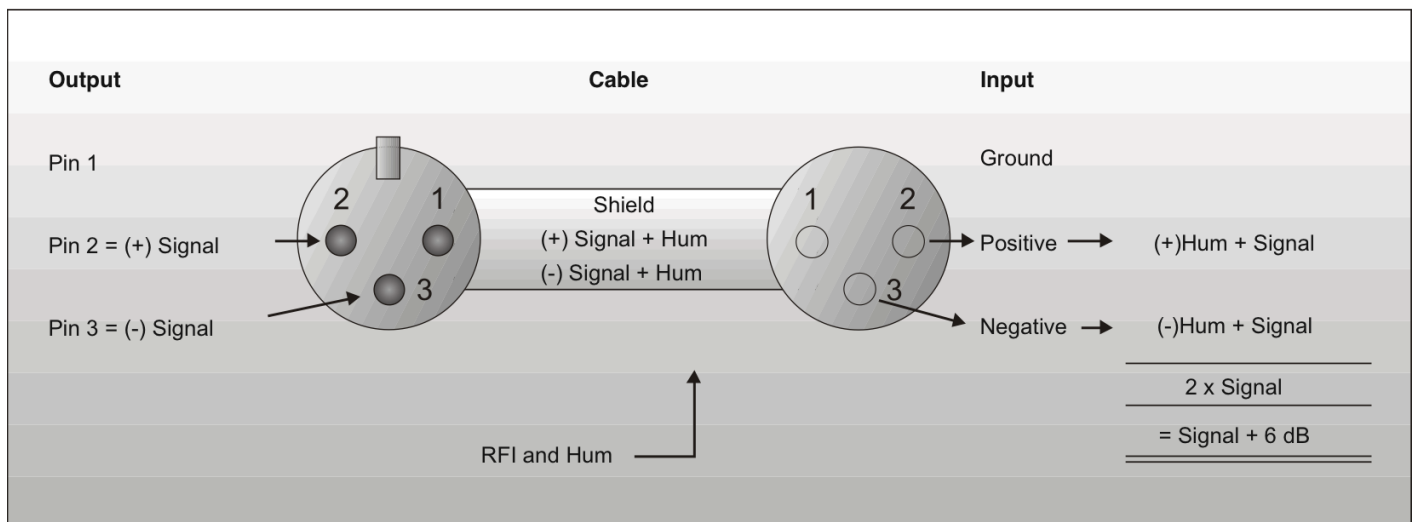

### Balanced use with XLR connectors

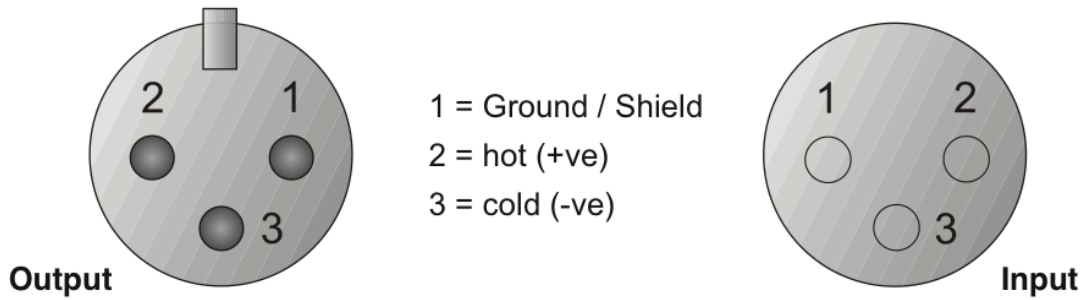

For unbalanced use PIN 1 and PIN 3 have to be bridged

## Maintenance

The DAP Audio CM-67 requires almost no maintenance. However, you should keep the unit clean. Disconnect the microphone and then wipe the cover with a damp cloth. Do not immerse in liquid. Do not use alcohol or solvents.

## Product Specifications

|                        |                                  |
|------------------------|----------------------------------|
| Model:                 | DAP Audio CM-67                  |
| Type:                  | Small Diaphragm Pencil Condenser |
| Frequency response:    | 30-20.000Hz (-3dB)               |
| Polar pattern:         | Cardioid                         |
| Sensitivity:           | 14mV/Pa -38dB                    |
| Max SPL:               | 128 dB                           |
| Impedance:             | 200 Ohms                         |
| Power supply:          | 48V phantom power                |
| Microphone connector:  | 3-pole XLR male                  |
| Dimensions microphone: | Ø50mm x 151mm                    |
| Weight :               | 0,390kg                          |

Design and product specifications are subject to change without prior notice.



Website: [www.Dap-audio.info](http://www.Dap-audio.info)  
Email: [service@highlite.nl](mailto:service@highlite.nl)



© 2011 Dap Audio.