



COM41 Beltpack Set

ORDERCODE D1409



Highlite International B.V.

Vestastraat 2
6468 EX Kerkrade
The Netherlands

SHOWELECTRONICS FOR PROFESSIONALS

Congratulations!

You have bought a great, innovative product from DAP Audio.
The DAP Audio COM-41 brings excitement to any venue.

You can rely on DAP Audio, for more excellent audio products.
We design and manufacture professional audio equipment for the entertainment industry.
New products are being launched regularly. We work hard to keep you, our customer, satisfied.
For more information: iwant@dap-audio.info

You can get some of the best quality, best priced products on the market from DAP Audio.
So next time, turn to DAP Audio for more great audio equipment.
Always get the best -- with DAP Audio !

Thank you!



Warning.....2
 Unpacking Instructions.....2
 Safety-instructions.....2
 Operating Determinations.....3
 Return Procedure.....3
 Claims.....3

Description.....4
 Features.....4
 Overview.....4

Installation.....7

Set Up and Operation.....7
 Set Up.....7
 Receiver volume adjustment.....8
 Transmitter audio gain adjustment.....8
 Adjusting the squelch threshold.....8
 Tips for achieving maximum performance.....8

Approval.....9

Declaration of conformity.....10

Connection Cables.....12

Maintenance.....13

Troubleshooting.....13

Product Specifications.....14

WARNING

**FOR YOUR OWN SAFETY, PLEASE READ THIS USER MANUAL CAREFULLY
BEFORE YOUR INITIAL START-UP!**

UNPACKING INSTRUCTIONS

Immediately upon receiving this product, carefully unpack the carton and check the contents to ensure that all parts are present, and have been received in good condition. Notify the dealer immediately and retain packing material for inspection if any parts appear damaged from shipping or the carton itself shows signs of mishandling. Save the carton and all packing materials. In the event that a fixture must be returned to the factory, it is important that the fixture be returned in the original factory box and packing.

Your shipment includes:



- Receiver
- Transmitter
- AC adapter
- Guitar cable
- Lavalier microphone
- Headset

 **CAUTION!** 
Keep this system away from rain and moisture!

SAFETY INSTRUCTIONS

Every person involved with the installation, operation and maintenance of this system has to:

- be qualified
- follow the instructions of this manual

 **CAUTION! Be careful with your operations.** 
**With a dangerous voltage you can suffer
a dangerous electric shock when touching the wires!**

Before you initial start-up, please make sure that there is no damage caused by transportation. Should there be any, consult your dealer and do not use the system.

To maintain perfect condition and to ensure a safe operation, it is absolutely necessary for the user to follow the safety instructions and warning notes written in this manual.

Please consider that damages caused by manual modifications to the system are not subject to warranty.

This system contains no user-serviceable parts. Refer servicing to qualified technicians only.

IMPORTANT:

The manufacturer will not accept liability for any resulting damages caused by the non-observance of this manual or any unauthorized modification to the device.

- Never remove warning or informative labels from the unit.
- Never leave any cables lying around.
- Do not open the device and do not modify the device.
- Do not connect this device to a dimmerpack.
- Do not switch the system on and off in short intervals, as this would reduce the system's life.
- Only use device indoor, avoid contact with water or other liquids.
- Avoid flames and do not put close to flammable liquids or gases.

- Always disconnect power from the mains, when device is not used or before cleaning! Only handle the power-cord by the plug. Never pull out the plug by tugging the power-cord.
- Make sure you don't use the wrong kind of cables or defective cables.
- Make sure to use the supplied AC adaptor only.
- Make sure that the power-cord is never crimped or damaged. Check the system and the power-cord from time to time.
- If system is dropped or struck, disconnect the power supply immediately. Have a qualified engineer inspect for safety before operating.
- If the system has been exposed to drastic temperature fluctuation (e.g. after transportation), do not switch it on immediately. The arising condensation water might damage your system. Leave the system switched off until it has reached room temperature.
- If your Dap Audio device fails to work properly, discontinue use immediately. Pack the unit securely (preferably in the original packing material), and return it to your Dap Audio dealer for service.
- Repairs, servicing and electric connection must be carried out by a qualified technician.
- WARRANTY: Till one year after date of purchase.

OPERATING DETERMINATIONS

If this system is operated in any other way, than the one described in this manual, the product may suffer damages and the warranty becomes void.

Any other operation may lead to dangers like short-circuit, burns, electric shock, etc.

Return Procedure

Returned merchandise must be sent prepaid and in the original packing, call tags will not be issued. Package must be clearly labeled with a Return Authorization Number (RMA number). Products returned without an RMA number will be refused. Highlite will not accept the returned goods or any responsibility. Call Highlite 0031-455667723 or mail aftersales@highlite.nl and request an RMA prior to shipping the fixture. Be prepared to provide the model number, serial number and a brief description of the cause for the return. Be sure to properly pack fixture, any shipping damage resulting from inadequate packaging is the customer's responsibility. Highlite reserves the right to use its own discretion to repair or replace product(s). As a suggestion, proper UPS packing or double-boxing is always a safe method to use.

Note: If you are given an RMA number, please include the following information on a piece of paper inside the box:

- 1) Your name
- 2) Your address
- 3) Your phone number
- 4) A brief description of the symptoms

Claims

The client has the obligation to check the delivered goods immediately upon delivery for any shortcomings and/or visible defects, or perform this check after our announcement that the goods are at their disposal. Damage incurred in shipping is the responsibility of the shipper; therefore the damage must be reported to the carrier upon receipt of merchandise.

It is the customer's responsibility to notify and submit claims with the shipper in the event that a fixture is damaged due to shipping. Transportation damage has to be reported to us within one day after receipt of the delivery.

Any return shipment has to be made post-paid at all times. Return shipments must be accompanied with a letter defining the reason for return shipment. Non-prepaid return shipments will be refused, unless otherwise agreed in writing.

Complaints against us must be made known in writing or by fax within 10 working days after receipt of the invoice. After this period complaints will not be handled anymore.

Complaints will only then be considered if the client has so far complied with all parts of the agreement, regardless of the agreement of which the obligation is resulting.

Description of the device

Features

The Com-41 is a UHF Wireless Microphone/ instrument beltpack set from Dap Audio.

- Plug and play
- Low battery indication
- Guitar cable lavalier microphone and headset included

The COM-41 wireless beltpack is a plug and play wireless starter package. It works on one frequency and it has no advanced menu's and settings. So this is the easiest way to get started with wireless systems and it will always work. The beltpack transmitter has an indication to warn you when your batteries run low. The package includes a guitar cable (active guitars only), lavalier microphone and headset so this set will offer you everything you need for many applications.

Overview



Fig. 1

- 1. Power switch.**
Turns receiver power on or off.
- 2. Diversity Signal Indicators.**
The A and B LED indicate which channel is receiving.
- 3. Audio level indicator**
Indicates the level of the incoming audio signal.
- 4. Volume control.**
Allows to adjust the output level. If the red LED of the audio level indicator is lit, lower the output volume control by turning counterclockwise. The red LED should only blink occasionally.



Fig. 2

- 5. Antenna A**
- 6. Balanced audio output connector (Low Z).**
- 7. 1/4" Phone jack audio output connector (Unbalanced High Z).**
- 8. Squelch Control.**
Adjust squelch control setting to emphasize either signal quality or system range. This control is factory preset and normally needs no adjustment. For more info see the section on Adjusting the squelch threshold on page 7.
- 9. Power input connector.**
Please use the supplied AC adapter only.
- 10. Antenna B**



Fig. 3

11. Power/standby switch.

This switch has three positions: On position turns the transmitter on while the off position turns the transmitter off. Switching the transmitter on or off can cause pop noises, therefore we suggest turning the **volume control (11)** on the receiver down when switching the transmitter on or off. If you want to switch off the transmitter off during pauses in the music we suggest using the standby position. In standby position, the input of the transmitter is muted without causing pop noises.

12. Low battery LED.

The LED will light red when the battery only has one hour or less of useful operating time.

13. Audio level control.

Use a small screwdriver to adjust the input level. For the connected device eg. Microphone or instrument

14. Input connector.

Miniature connector allows connection to a Lavalier microphone, headset microphone or instrument adapter cable.

15. Battery compartment.

16. Input switch.

This 3 position switch allows you to set the optimal gain/impedance for guitar, dynamic microphone or lavalier microphone.

Left position: Guitar.

Middle position: Dynamic microphone (headset).

Right position: Lavalier.

Installation

Remove all packing materials from the Com-41. Check that all foam and plastic padding is removed.

**Always disconnect from electric mains power supply before cleaning or servicing.
Damages caused by non-observance are not subject to warranty.**

Set Up and Operation

Before plugging the unit in, always make sure that the power supply matches the product specification voltage.

1. Refer to Figure 4. Connect the supplied power AC adapter into the **DC input Connector (9)** at the back of the receiver. Plug the adapter in a wall socket or other AC power source. Set the **Power/standby switch (11)** on the receiver in **Stdby** position. Turn on the **power switch (1)** on the front of the receiver, the red power LED will light.
2. Insert the supplied antennas in the **antenna sockets (5,10)** and rotate fully clockwise. Position the antennas at an angle of 45 degrees.
3. Connect the receiver's **XLR audio output (6)** to the mixer input using a XLR to XLR audio cable or connect the receiver's **1/4" jack output connector (7)** to your amplifiers input using a 1/4" phone plug cable.

Headset:

Slide the receiver's battery cover open and then remove it carefully, set the **input switch (16)** in the second (middle) position. Replace the receiver's battery cover and slide it back in position. Connect the plug to the transmitter **input jack (14)**. Rotate the ring to lock the plug.

Lavalier:

Slide the receiver's battery cover open and then remove it carefully, set the **input switch (16)** in the last (right) position. Replace the receiver's battery cover and slide it back in position. Connect the plug to the transmitter **input jack (14)**. Rotate the ring to lock the plug.

Guitar cable:

Slide the receiver's battery cover open and then remove it carefully, set the **input switch (16)** in the first (left) position. Replace the receiver's battery cover and slide it back in position. Connect your receiver's **1/4" jack output connector (10)** to your amplifier's input using a standard guitar cable.

Connect your guitar or bass to the transmitter **input jack (14)** with the supplied instrument adapter and rotate the ring to lock the connector.

Adjust the volume control of your guitar to the desired level. To match the wireless to that of a wired system, see the section Receiver Volume adjustment for the guitarist UHF on page 7.

4. Slide the recessed transmitter **power/stby switch (11)** in the **on** position. The indicator will light
5. for a moment and the receiver's **A/B LED's (3)** will light.
6. Adjust the receiver **volume control (4)** and the volume adjustment of the connected mixer or amplifier to a suitable level. Transmitter gain may need adjustment. See the section Transmitter gain adjustment on page 7.
7. If the performance is over, turn off the sound system and slide the transmitter's **power/stdby switch (11)** in the off position to conserve battery power.

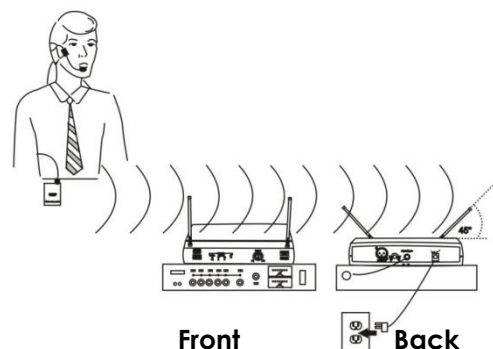
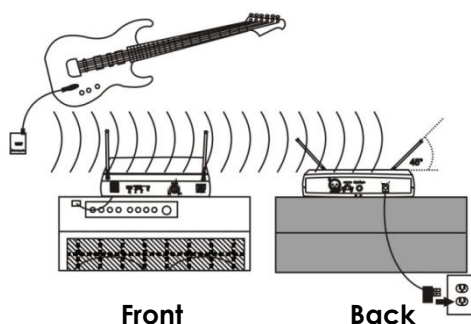

Receiver volume adjustment when using the com 41 with a guitar.

1. Plug your instrument directly in the guitar/ bass amp. Set volume and tone controls on both the instrument and amplifier for a clean signal with the desired tone and volume. Do not change these setting for the rest of the volume adjustment.
2. Unplug instrument from the amplifier input and plug into the transmitter. Plug the receiver into the amplifier input.
3. Adjust the receiver volume control until sound quality matches that achieved in step 1.

Transmitter audio gain adjustment.

The audio gain control has been factory set at the mid-range position for optimum performance in most applications. Adjustment may be necessary for singers with soft voices or low output guitars.

- To increase the gain, rotate the transmitter gain control clockwise with a screwdriver .
- To reduce gain, rotate the transmitter gain control counterclockwise with a screwdriver.

To set the audio gain back to factory preset, rotate the transmitter audio gain control to the mid position.

Adjusting the squelch threshold.

Interference due to other transmission links can be eliminated as follows:

- Switch off the transmitter. The receiver should no longer receive a signal.
- If the receiver still receives a signal, use the **squelch control (8)** to increase the squelch threshold so that the signal will no longer be received. If the signal cannot be eliminated in this way, set the transmitter and the receiver to a different channel.
- Switch on the transmitter again and check if the receiver receives the transmitter signal.

Note:

If the squelch threshold is adjusted to high, the transmission range will be reduced. Therefore always adjust the squelch control to the lowest possible setting.

Tips for achieving maximum performance.

- Make sure you can always see a receiver antenna from the transmitter position.
- Keep the distance from transmitter to receiver antenna as short as possible.
- Point the receiver antennas away from each other at 45 degrees angle from vertical position.
- Avoid placing the receiver antennas near metal surfaces and obstructions.
- Replace battery as soon as low battery LED lights.
- If stacking or rack mounting receivers in a multiple system setup. Do not allow antennas to cross.
- Perform a walk-through before performance or presentation. If dead spots are found, adjust the location of the receiver. If dead spots remain, mark the dead spots and avoid them.

Approval

The DAP D1409 is a Class II wireless devices.

863,550 Mhz for use in: Belgium, Denmark, Germany, Luxemburg, Netherlands, Norway, Poland, Spain, Sweden, Switzerland, United Kingdom.

Exclusion of liability

The frequency tables in this publication are made according to national laws and regulations. The frequencies are checked on a regular basis. We don't take any responsibility for eventual discrepancies between our listed frequencies and the frequencies actually approved in a given country. We strongly suggest you to inform in your own country or region for any changes or adaptations regarding the allowed frequencies.

Please refer to your authority as listed below:

Telecoms & Postal Regulatory Authorities in Europe

Austria Rundfunk und Telekom Regulierungs-GmbH	www.rtr.at
Belgium Belgian Institute of postal services and telecommunications (BIPT)	www.bipt.be
Czech Republic Czech Telecommunication Office	www.ctu.cz
Denmark National Telecom Agency	www.tst.dk
Finnland Finnish Communications Regulatory Authority (FICORA)	www.ficora.fi
France Autorité de Régulation des Télécommunications (ART)	www.art-telecom.fr
Germany Die Bundesnetzagentur	www.bundesnetzagentur.de
Greece National Telecommunications Commission (EET)	www.eett.gr
Hungary Communication Authority (HIF)	www.hif.hu
Iceland Post and Telecom Administration (PTA)	www.pta.is
Ireland Commission for Communications Regulation (ComReg)	www.comreg.ie
Italy Italian Communications Authority (AGC)	www.agcom.it
Latvia Telecommunication State Inspection	www.vei.lv
Liechtenstein Office for Communications (AK)	www.ak.li
Lithuania Radio Administration	www.rrt.lt
Luxembourg Institut Luxembourgeois des Télécommunications (ILT)	www.etat.lu/ILT
Netherlands Onafhankelijke Post en Telecommunicatie Autoriteit (OPTA)	www.opta.nl
Agentschap Telecom Ministry of Economic Affairs	www.agentschap-telecom.nl www.ez.nl
Norway Norwegian Post and Telecommunications Authority (NPT)	www.npt.no
Poland Urząd Regulacji Telekomunikacji (URT)	www.urt.gov.pl
Portugal Autoridad Nacional De Comunicações (ICP-Anacom)	www.anacom.pt
Slovenia Agencija za telekomunikacije, radiodifuzijo in pošto	www.atrp.si



DECLARATION OF CONFORMITY

Supplier Details

Name

Highlite International BV

Address

Vestastraat 2
6468EX Kerkrade
The Netherlands

Product Details

Product Name

COM-41 Beltpack Set

Ordercode

D1409

Trade Name

DAP AUDIO

Applicable Standards Details

Low Voltage Directives : 2006/95/EC

EN 60065: 2002+A1: 2006+A2: 2010+A11: 2008+A12: 2011

Supplementary Information

The conformity to above standards is verified by Waltek services CO., LTD.

Declaration

I hereby declare under our sole responsibility that the product mentioned above to which this declaration relates complies with the above mentioned standards and Directives

Highlite International BV.
Vestastraat 2, 6468 EX Kerkrade,
The Netherlands

Name

S. ildiz

Issued Date

Oct. 14, 2011

Signature of representative



DECLARATION OF CONFORMITY

Supplier Details

Name

Highlite International BV

Address

Vestastraat 2
6468EX Kerkrade
The Netherlands

Product Details

Product Name

COM-41 Backpack Set

Ordercode

D1409

Trade Name

DAP AUDIO

Applicable Standards Details

R&TTE Directives : 1999/5/EC

Applied Specifications / Standards

EN 301489-1 V1.9.1: 2011
EN 301489-9 V1.4.1: 2007
EN 300422-1 V1.4.2: 2011
EN 300422-2 V1.3.1: 2011
EN 50371: 2002

The product shall be marked with the CE conformity marking and our Notified Body number as shown on the right.

CE1177!

Supplementary Information

The conformity to above standards is verified by Timco Engineering (Notified Body).

Declaration

I hereby declare under our sole responsibility that the product mentioned above to which this declaration relates complies with the above mentioned standards and Directives

Name

Issued Date

S. ildiz

Oct 09, 2011

Highlite International BV.
Vestastraat 2, 6468 EX Kerkrade,
The Netherlands

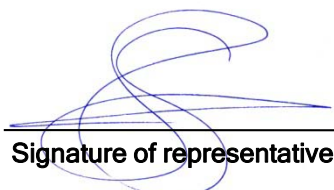

Signature of representative

Connection Cables

Take care of the connector cables, always holding them by the connectors and avoiding knots and twists when coiling them: This gives the advantage of increasing their life and reliability, which is always to your advantage.

Periodically check that your cables are in good condition, that they are correctly wired and that all their contacts are perfectly efficient: a great number of problems (faulty contacts, ground hum, discharges, etc.) are caused entirely by using unsuitable or faulty cables.

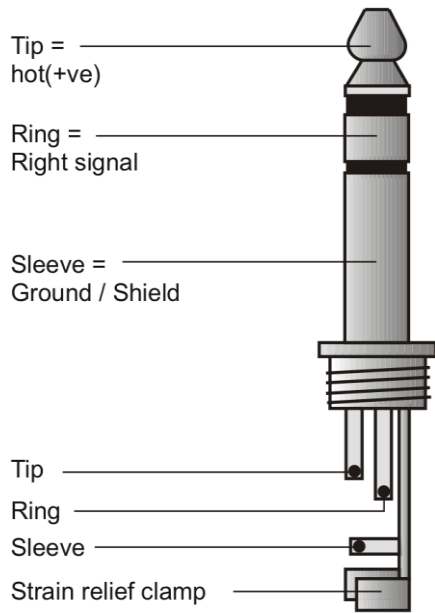
Headphones plug



Unbalanced mono 1/4" jack plug

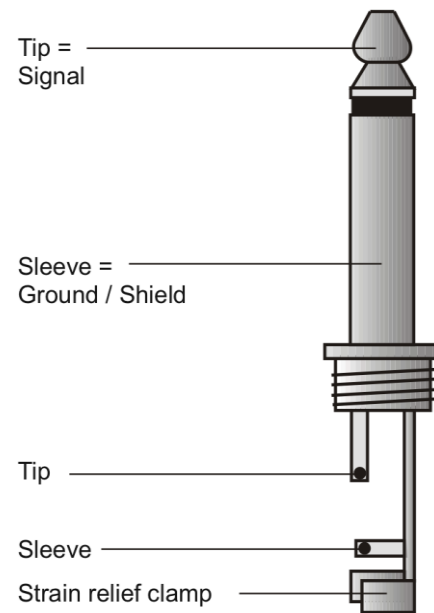

Balanced mono 1/4" jack

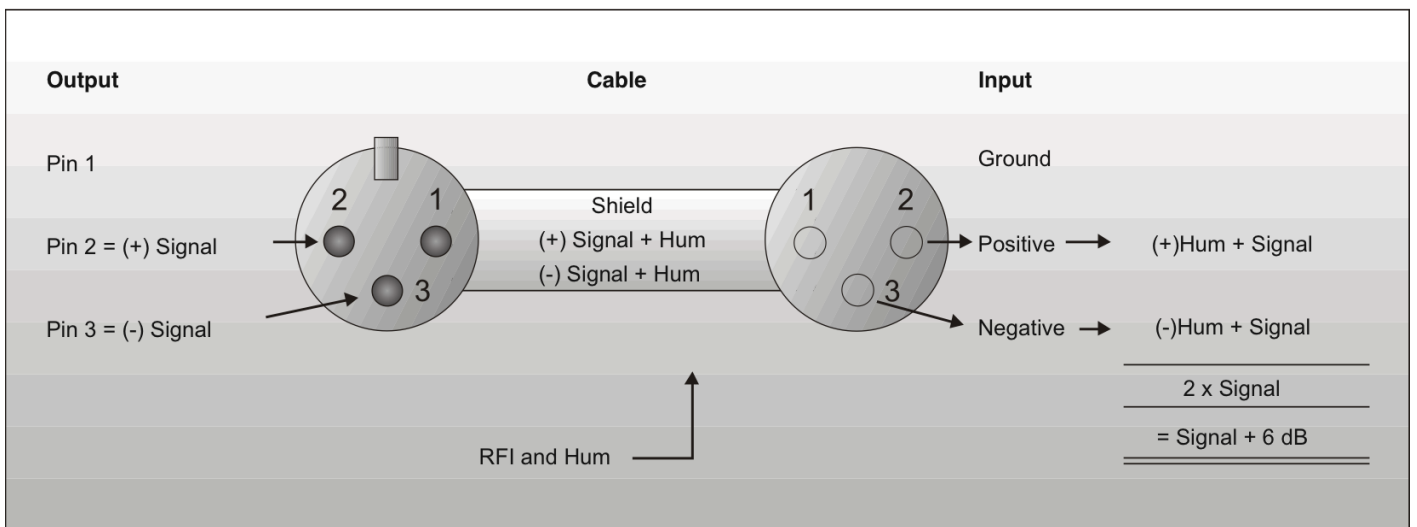
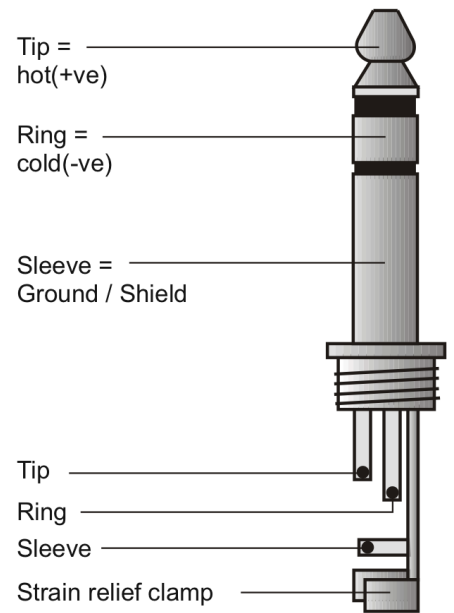

Compensation of interference with balanced connections

Balanced use with XLR connectors

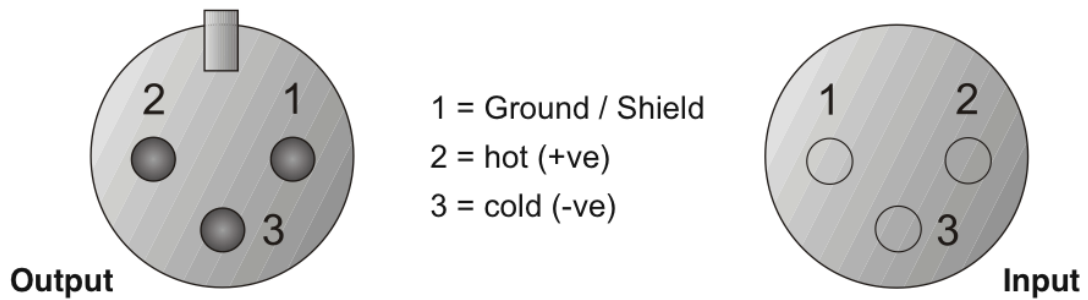

For unbalanced use PIN 1 and PIN 3 have to be bridged

Maintenance

The DAP Audio COM-41 requires almost no maintenance. However, you should keep the unit clean. Disconnect the mains power supply, and then wipe the cover with a damp cloth. Do not immerse in liquid. Do not use alcohol or solvents.

Keep connections clean. Disconnect electric power, and then wipe the DMX and audio connections with a damp cloth. Make sure connections are thoroughly dry before linking equipment or supplying electric power.

Troubleshooting

DAP Audio COM-41

This troubleshooting guide is meant to help solve simple problems. If a problem occurs, carry out the steps below in sequence until a solution is found. Once the unit operates properly, do not carry out following steps.

1. If the device does not operate properly, unplug the device.
2. Check power from the wall, all cables, the fuse, etc.
3. If all of the above appears to be O.K., plug the unit in again.
4. If nothing happens after 30 seconds, unplug the device.
5. Return the device to your DAP Audio dealer.

Product Specification

Modulation: FM with thre diversity
Frequency: 863.550 Mhz
Frequency responce: 50Hz - 18Khz
THD: < 1,0 % (1Khz)
Maximum distance: Up to 50 meters

Receiver::

Indications: Antenna AB, AF signal
Controls: On/Off switch, volume, sqelch
Audio outputs: XLR male balanced, 1/4" jack unbalanced
Power supply: DC 12--15V 300mA
Dimensions: 47 x 210 x 160 mm (HxWxD)
Weight: 0,4 Kg

Transmitter

Connector: 3,5mm jack
Input impedance: 4Kohm
Headset mic: Condenser, cardioid
Lavelier mic: Condenser, cardioid
Indications: Low battery
Controls: On/Off/Standby switch, Squelch
RF output power: 10mW
Battery: 9V Block
Dimensions: 108 x 64 x 25 mm (HxWxD)
Weight: 0,1 Kg



Design and product specifications are subject to change without prior notice.



Website: www.Dap-audio.info
Email: service@highlite.nl



© 2011 Dap Audio.