

e 902 Dynamic cardioid instrument microphone for kick drums, bass guitar amps, tuba, and other bass instruments

FEATURES

- Frequency response optimized for kick drum
- Very fast attack
- Exceptionally clean and clear pick-up of the deepest bass signals
- Integral stand mount
- Hum compensating coil
- Shock mounted capsule
- Robust metal body

The cardioid **e 902** is a dynamic instrument microphone especially designed for deep bass frequency instruments such as kick drums, bass guitar amps and tuba. Faithfully reproducing the lowest frequencies and handling the highest SPLs, the e 902 is your bottom end's best friend.



ARCHITECT'S SPECIFICATIONS

The microphone shall be a dynamic cardioid designed for use with bass instruments. It shall have a rugged metal body with an integral stand mount and a shock-mounted capsule. The microphone shall be fitted with a hum compensating coil. The frequency response shall be 40 Hz – 16,000 Hz and the sensitivity (free field, no load) shall be 0.2 mV/Pa at 1 kHz and 0.6 mV/Pa at 60 Hz. Nominal impedance shall be 350, with a min. terminating impedance of 1 kΩ. The microphone shall provide a 3-pin XLR connector. Dimensions shall be 60 x 128.5 mm (2.36" x 5.06"). Weight shall be 440 grams (15.52 oz). The microphone shall be the Sennheiser e 902.

TECHNICAL DATA

Transducer principle	dynamic
Pick-up pattern.....	cardioid
Frequency response	40.....16,000 Hz
Sensitivity (free field, no load)	0.2 mV/Pa at 1 kHz;
	0.6 mV/Pa at 60 Hz
Nominal impedance.....	350 Ohm
Min. terminating impedance.....	1000 Ohm
Connector.....	XLR-3
Dimensions.....	128.5 x 60 mm
Weight.....	440 g

DELIVERY INCLUDES

- 1 e 902
- 1 pouch
- Instructions for use

Dynamic cardioid instrument microphone for kick drums,
e 902 bass guitar amps, tuba, and other bass instruments

DIMENSIONS

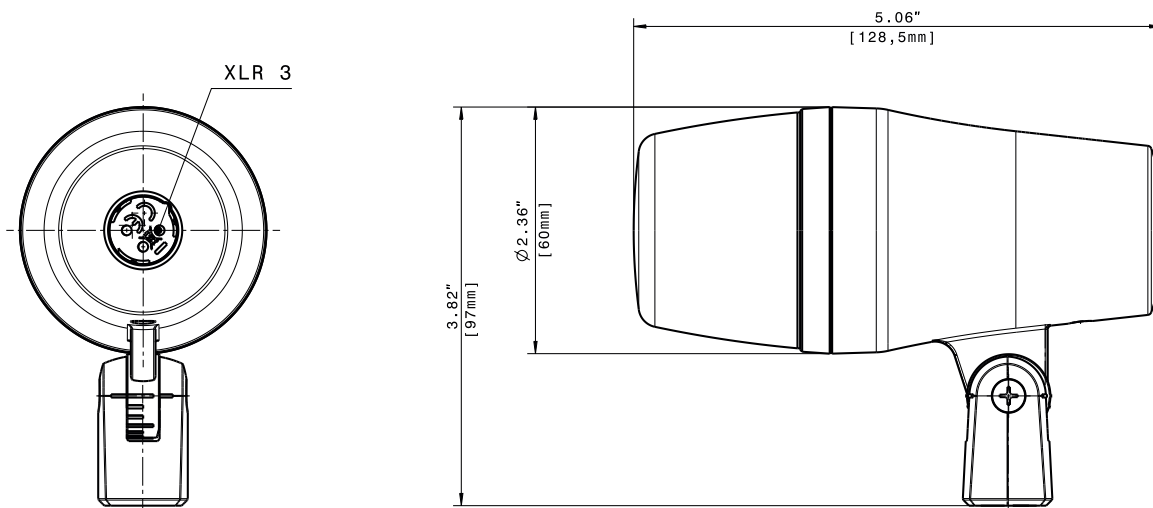

FREQUENCY RESPONSE

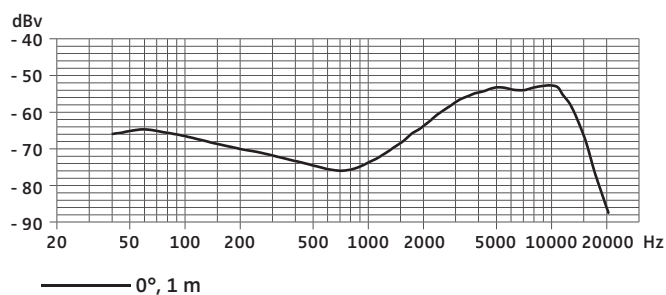

POLAR PATTERN

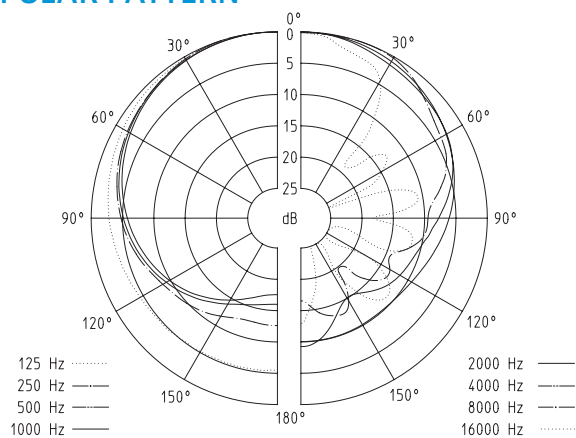

Sennheiser electronic GmbH & Co. KG
Am Labor 1, 30900 Wedemark, Germany
www.sennheiser.com

