

HELLBABE HB01



Thank you for showing your confidence in us by purchasing the BEHRINGER HELLBABE HB01. This professional Wah-Wah pedal is specially designed to provide everything you need for all-style classic and modern sounds. Thanks to its high-performance features like flexible Q control, freely adjustable heel-down frequency range (perfect for use with bass guitars), tunable boost function and much more you're armed with a tool for serious musicians yearning for the most up-to-date sounds to add new dimensions to their creativity.

WHERE TO PUT YOUR WAH-WAH

Most guitar players put their Wah-Wah pedal before time based effects like reverb, flanger, chorus, vibrato etc. This assures that the effects are added to the Wah-Wah sound. Even all kinds of distortion/overdrive effects should be placed before this unit to achieve best tone results.

1. CONTROLS

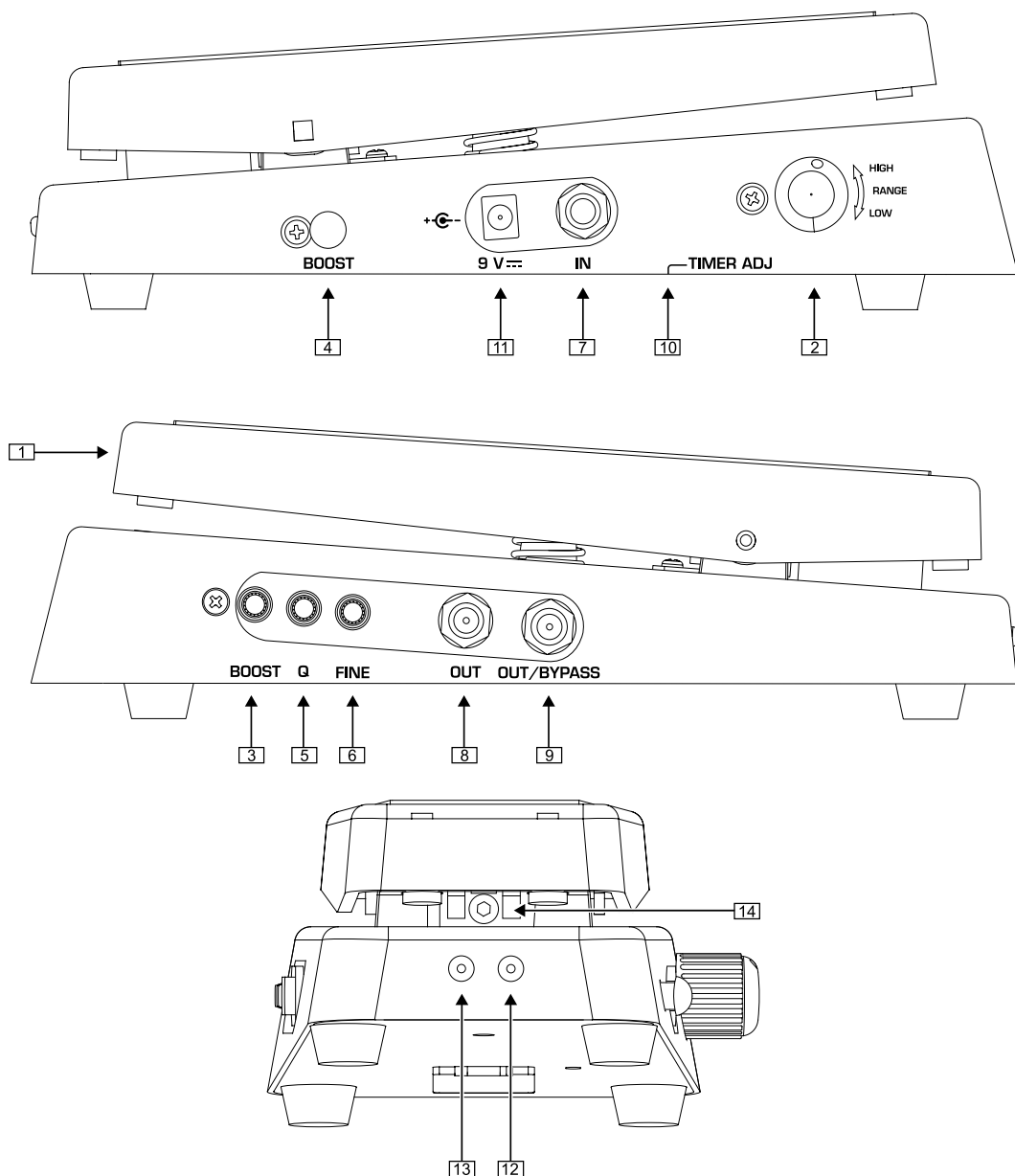

- 1 This is the *pedal* of the HB01. The unit will be activated as soon as you put your foot on and move it. By taking your foot from the pedal the effect will be deactivated. Depending on the timer adjustment (see 10) the HB01 remains active for a few seconds after that.
- 2 The *RANGE* control lets you extend the heel-down frequency to match the frequency range of bass guitars for example (440 Hz to 250 Hz).
- 3 The *BOOST* switch activates the boost function that allows to increase the output level when the effect is activated.
- 4 The *BOOST* control adjusts the amount of output boost (max. +15 dB). This control is just active when the BOOST switch is set to ON.
- 5 The *Q* control allows to change the shape of the filter peak. High Q settings (turned to right position) produce a large, selective filter peak with a high output level. Low Q settings (turned to left position) provide a lower output level with a subtle, broad filter peak producing less vocal effect.
- 6 Turning the *FINE* control allows to extend the toe-down frequency of the sweep range up to 2.2 kHz.
- 7 Use this 1/4" TS *IN* connector to plug in the instrument cable.
- 8 The 1/4" TS *OUT* connector sends the effected signal to your amp.
- 9 The 1/4" TS *OUT/BYPASS* connector can be used as second output or as bypass, hard wired to the input, to play out the unaffected signal.
- 10 The *TIMER ADJ* control (accessable through a hole in the housing) is needed to adjust the time the effect remains active after taking your foot from the pedal.
- 11 Use the 9 V connection to plug in a 9 V power supply (not included).
- 12 The *STATUS-LED* illuminates when the effect is activated.
- 13 The *BOOST-LED* illuminates when the boost function is activated.
- 14 The *rocker screw* allows to adjust the resistance of the rocker mechanism.

The *BATTERY COMPARTMENT* is located at the bottom of the unit. Open the lid to install or replace the 9 V battery.

⚠ The HB01 has no on/off switch. As soon as you insert the jack into the IN connector, the HB01 begins running. When not using the HB01, remove the jack from the IN connector. This extends the life of the battery.

The *SERIAL NUMBER* is located at the bottom of the unit.

2. WARRANTY

For our current warranty terms, please refer to our website at <http://www.behringer.com>.

3. SPECIFICATIONS

Input	Connector	1/4" TS
	Impedance	1 MΩ
Output	Connector	1/4" TS
	Impedance	1 kΩ
Output/Bypass	Connector	1/4" TS
	Impedance	1 kΩ
Power supply		9 V, 100 mA DC regulated
		PSU-SB-CN BEHRINGER 220 VAC adaptor China
		PSU-SB-EU BEHRINGER 230 VAC adaptor Europe
		PSU-SB-JP BEHRINGER 100 VAC adaptor Japan
		PSU-SB-SAA BEHRINGER 240 VAC adaptor Australia
		PSU-SB-UK BEHRINGER 240 VAC adaptor UK
		PSU-SB-UL BEHRINGER 120 VAC adaptor USA
Power connector		2 mm DC jack, negative center
Battery		9 V type 6LR61
Power consumption		30 mA
Dimensions (H x W x D)		approx. 99 mm (3 9/10") x 120 mm (4 3/4") x 254 mm (10")
Weight		approx. 0.46 kg (1.01 lbs)

BEHRINGER is constantly striving to maintain the highest professional standards. As a result of these efforts, modifications may be made from time to time to existing products without prior notice. Specifications and appearance may therefore differ from those listed or shown.

4. SAFETY INSTRUCTIONS

Do not use near water, or install near heat sources. Use only authorized attachments/accessories. Do not service product yourself. Contact our qualified servicing personnel for servicing or repairs, **especially when power supply cord or plug is damaged.**

No utilizar cerca de agua o instalar cerca de fuentes de calor. Utilice sólo accesorios y aditamentos autorizados. No intenté reparar el producto usted mismo. Contacte a nuestro personal técnico cualificado para servicio y reparaciones, **especialmente cuando la fuente o el cable de alimentación estén dañados.**

Не эксплуатируйте прибор вблизи от источников воды и тепла. Применяйте только авторизованные дополнительные устройства. Никогда не ремонтируйте прибор самостоятельно. Ремонт может производить только квалифицированный специализированный персонал, **особенно при повреждениях сетевого провода или сетевой вилки.**

Ne pas utiliser ni installer à proximité de liquide ou de sources de chaleur. Utilisez exclusivement les accessoires autorisés. Ne réalisez pas de maintenance vous-même sur le produit. Contactez notre personnel technique pour tout service ou réparation, **particulièrement si le cordon ou le connecteur du bloc d'alimentation est endommagé.**

Betreib das Gerät nicht in der Nähe von Wasser oder Wärmequellen. Verwende bitte nur autorisiertes Zubehör. Führe bitte keinerlei Reparaturen am Gerät eigenständig durch. Reparaturen sind nur von qualifiziertem Fachpersonal vorzunehmen, **insbesondere bei Beschädigungen des Netzkabels oder Netzsteckers.**

Non usare in prossimità dell'acqua o installare vicino a fonti di calore. Usare solo collegamenti ed accessori approvati. Non tentare di riparare l'apparecchio da sé. Contattare il nostro personale specializzato per eseguire operazioni di manutenzione e riparazione, **in particolare se i cavo di alimentazione e la spina sono danneggiati.**

Niet gebruiken in de buurt van water of warmtebronnen. Gebruik uitsluitend geautoriseerde uitbreidingen/originele accessoires. Probeer nooit zelf het apparaat te repareren. Neem voor reparaties of onderhoud contact op met de leverancier, **met name wanneer het netsnoer of de stekker van het netsnoer beschadigd is.**

Nie używać w pobliżu wody ani nie instalować w pobliżu źródeł ciepła. Stosować wyłącznie dodatki/akcesoria dopuszczone przez producenta. Nie naprawiać urządzenia samodzielnie. Serwisowanie i naprawy zlecać naszemu wykwalifikowanemu personelowi, szczególnie w przypadku uszkodzeń przewodu lub wtyku sieciowego.

Älä käyttää laitetta veden tai lämmönlähteiden lähellä. Käytä vain hyväksytyjä lisätarvikkeita. Älä tee laitteeseen itse minkäänlaisia korjauksia. Ainoastaan pätevä ammattihenkilökunta saa suorittaa korjaukset; tämä koskee **erityisesti vaurioituneita verkkoakaapeleita tai -pistokkeita.**

Må ikke anvendes i nærheden af vand eller installeres i nærheden af varmeeenheder. Brug kun godkendte tilslutninger/tilbehør. Forsøg ikke selv at reparere produktet. Kontakt vores kvalificerede servicepersonale for at få udført service og reparation, **især hvis strømforsyningsledningen eller stikket er beskadiget.**

Får inte användas i närheten av vatten eller installeras nära värmekällor. Använd endast godkända delar/tilbehör. Utför aldrig själv någon service på produkten. Kontakta vår kvalificerade servicepersonal för service eller reparationer, **särskilt om det förekommer skador på strömkabeln eller stickkontakten.**

Não utilize na proximidade de água, nem instale perto de fontes de calor. Use apenas conexões e acessórios autorizados. Não repare o seu produto. Contacte o nosso pessoal qualificado para consertos ou reparações, **especialmente se o cabo ou a tomada de alimentação estiverem danificados.**

Μη χρησιμοποιείτε τη συσκευή κοντά σε νερό και μην την εγκαθιστάτε κοντά σε πηγές θερμότητας. Χρησιμοποιείτε μόνο εγκεκριμένα εξαρτήματα/παρελκόμενα. Μην εκτελείτε οι ίδιοι εργασίες σέρβις. Για την εκτέλεση εργασιών σέρβις ή επισκευής, επικοινωνήστε με το ειδικευμένο προσωπικό σέρβις της εταιρείας μας, **ιδιαίτερα όταν έχει προκληθεί ζημιά στο καλώδιο ή το βύσμα παροχής ρεύματος.**

水分の近くや、ヒーターなど熱気のある場所では使用しないでください。正式に認可された付属品のみを使用してください。製品はご自分では決して修理せず、特に電源コードもしくはプラグが損傷した場合には、必ず製品サービスおよびリペアの資格を有した当社の担当員にご相談ください。

不要在靠近水源的地方使用，或在靠近热源的地方安装。只使用经过许可的附件/配件。不要自己进行产品维修，**尤其是当电源线或插座损坏的时候**，请联系我们的专业服务人员有关产品维修事宜。

Die deutsche Anleitung ist erhältlich @ www.behringer.com
 Manuel francophone en téléchargement sur www.behringer.com
 Manual en español disponible en www.behringer.com
 Manuali italiani disponibili @ www.behringer.com
 Русскоязычное руководство @ www.behringer.com
 Polska instrukcja dostępna jest pod adresem @ www.behringer.com
 Nederlandse handleiding beschikbaar @ www.behringer.com
 Suomenkielinen käyttöohje saatavilla osoitteesta www.behringer.com
 Svensk manual finns tillgänglig på www.behringer.com
 Dansk vejledning findes på @ www.behringer.com
 Manual português disponível @ www.behringer.com
 Ελληνικό εγχειρίδιο υπάρχει διαθέσιμο στη διεύθυνση www.behringer.com
 日本語版マニュアル @ www.behringer.com
 使用说明书可在 www.behringer.com 下载

Technical specifications and appearance subject to change without notice. The information contained herein is correct at the time of printing. The names of companies, institutions or publications pictured or mentioned and their respective logos are registered trademarks of their respective owners. Their use neither constitutes a claim of the trademarks by BEHRINGER® nor affiliation of the trademark owners with BEHRINGER®. BEHRINGER® accepts no liability for any loss which may be suffered by any person who relies either wholly or in part upon any description, photograph or statement contained herein. Colours and specification may vary slightly from product. Products are sold through our authorised dealers only. Distributors and dealers are not agents of BEHRINGER® and have absolutely no authority to bind BEHRINGER® by any express or implied undertaking or representation. No part of this manual may be reproduced or transmitted in any form or by any means, electronic or mechanical, including photocopying and recording of any kind, for any purpose, without the express written permission of BEHRINGER Spezielle Studioteknik GmbH. BEHRINGER® is a registered trademark. ALL RIGHTS RESERVED. © 2005 BEHRINGER Spezielle Studioteknik GmbH, Hanns-Martin-Schleyer-Str. 36-38, 47877 Willich-Münchheide II, Germany. Tel. +49 2154 9206 0, Fax +49 2154 9206 4903